

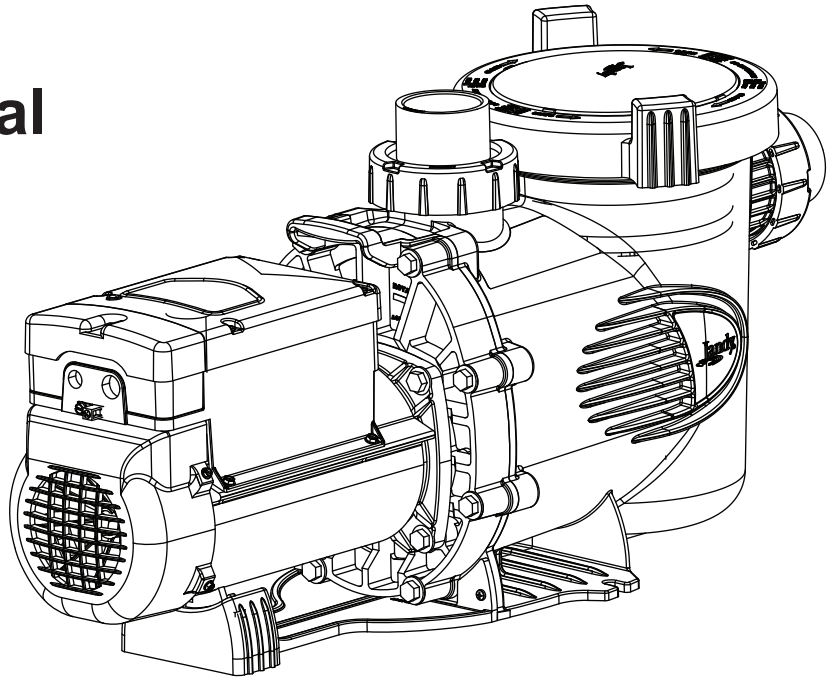

Installation and Operation Manual

ePump™ Series Pumps



WARNING

FOR YOUR SAFETY: This product must be installed and serviced by a professional service technician, qualified in pool/spa installation. The procedures in this manual must be followed exactly. Improper installation and/or operation can create dangerous electrical hazards, which can cause high voltages to run through the electrical system, possibly causing death, serious injury or property damage. Improper installation and/or operation will void the warranty.



ATTENTION INSTALLER: This manual contains important information about the installation, operation and safe use of this product. This information should be given to the owner/operator of this equipment.

Table of Contents

<p>Section 1. Important Safety Instructions 4</p> <p style="padding-left: 20px;">1.1 Safety Instructions 4</p> <p style="padding-left: 20px;">1.2 Pool Pump Suction Entrapment Prevention Guidelines 6</p> <p>Section 2. General Description 8</p> <p style="padding-left: 20px;">2.1 Introduction 8</p> <p style="padding-left: 20px;">2.2 Description 8</p> <p>Section 3. Installation Information 8</p> <p style="padding-left: 20px;">3.1 Plumbing 8</p> <p style="padding-left: 40px;">3.1.1 Preparation Information 8</p> <p style="padding-left: 40px;">3.1.2 Pump Location 8</p> <p style="padding-left: 40px;">3.1.3 Pipe Sizing 9</p> <p style="padding-left: 20px;">3.2 Electrical Installation 10</p> <p style="padding-left: 40px;">3.2.1 Voltage Checks 10</p> <p style="padding-left: 40px;">3.2.2 Bonding and Grounding 10</p> <p style="padding-left: 40px;">3.2.3 Electrical Wiring 10</p> <p style="padding-left: 40px;">3.2.4 Installing the Controller 11</p> <p style="padding-left: 20px;">3.3 ePump Dip Switch Settings 12</p> <p style="padding-left: 20px;">3.4 Pressure Testing 12</p> <p style="padding-left: 40px;">3.4.1 Replace Blue Pressure Test O-ring if Necessary 13</p> <p style="padding-left: 20px;">3.5 Conduct Pressure Test 14</p> <p>Section 4. Operation 14</p> <p style="padding-left: 20px;">4.1 Start-up 14</p>	<p>Section 5. Service and Maintenance 15</p> <p style="padding-left: 20px;">5.1 Routine Maintenance 15</p> <p style="padding-left: 20px;">5.2 Winterizing the Pump 15</p> <p>Section 6. Troubleshooting and Repair 16</p> <p style="padding-left: 20px;">6.1 Troubleshooting 16</p> <p style="padding-left: 20px;">6.2 Service Technician Maintenance 18</p> <p style="padding-left: 40px;">6.2.1 Blocked Impeller 18</p> <p style="padding-left: 40px;">6.2.2 Impeller Removal and Replacement 18</p> <p style="padding-left: 40px;">6.2.3 Mechanical Seal Replacement 21</p> <p style="padding-left: 40px;">6.2.4 Variable Speed Drive Electronics Replacement 22</p> <p style="padding-left: 40px;">6.2.5 Motor Replacement 23</p> <p>Section 7. Product Specifications and Technical Data 24</p> <p style="padding-left: 20px;">7.1 Replacement Parts List and Exploded View 24</p> <p style="padding-left: 20px;">7.2 Performance Curves 26</p> <p style="padding-left: 20px;">7.3 Physical and Operational Specifications 27</p> <p style="padding-left: 40px;">7.3.1 Specifications 27</p> <p style="padding-left: 40px;">7.3.2 Dimensions 27</p> <p style="padding-left: 20px;">7.4 Replacement Motor Guide 27</p>
--	---

EQUIPMENT INFORMATION RECORD

DATE OF INSTALLATION _____

INSTALLER INFORMATION _____

INITIAL PRESSURE GAUGE READING (WITH CLEAN FILTER) _____

PUMP MODEL _____

HORSEPOWER _____

NOTES: _____

Section 1. Important Safety Instructions

READ AND FOLLOW ALL INSTRUCTIONS

1.1 Safety Instructions

All electrical work must be performed by a licensed electrician and conform to all national, state, and local codes. When installing and using this electrical equipment, basic safety precautions should always be followed, including the following:

 **WARNING**

RISK OF SUCTION ENTRAPMENT HAZARD, WHICH, IF NOT AVOIDED, CAN RESULT IN SERIOUS INJURY OR DEATH. Do not block pump suction, as this can cause severe injury or death. Do not use this pump for wading pools, shallow pools, or spas containing bottom drains, unless the pump is connected to at least two (2) functioning suction outlets. Drain covers must be certified to the latest published edition of ANSI/ASME A112.19.8.

 **WARNING**

To reduce the risk of injury, do not permit children to use this product.

 **WARNING**

To reduce the risk of property damage or injury, do not attempt to change the backwash (multiport, slide, or full flow) valve position with the pump running.

 **WARNING**

Jandy Pumps are powered by a high-voltage electric motor and must be installed by a licensed or certified electrician or a qualified swimming pool service technician.

 **WARNING**

Due to the potential risk of fire, electric shock, or injuries to persons, Jandy Pumps must be installed in accordance with the National Electrical Code (NEC), all local electrical and safety codes, and the Occupational Safety and Health Act (OSHA). Copies of the NEC may be ordered from the National Fire Protection Association, 470 Atlantic Ave., Boston, MA 02210, or from your local government inspection agency.

 **WARNING**

Incorrectly installed equipment may fail, causing severe injury or property damage.

 **WARNING**

- Do not connect system to an unregulated city water system or other external source of pressurized water producing pressures greater than 35 PSI.
- Trapped air in the system can cause the filter lid to be blown off, which can result in death, serious personal injury, or property damage. Be sure all air is out of the system before operating.

⚠ WARNING

To minimize risk of severe injury or death, the filter and/or pump should not be subjected to the piping system pressurization test.

Local codes may require the pool piping system to be subjected to a pressure test. These requirements are generally not intended to apply to the pool equipment, such as filters or pumps.

Jandy pool equipment is pressure tested at the factory.

If, however, the WARNING cannot be followed and pressure testing of the piping system must include the filter and/or pump, **BE SURE TO COMPLY WITH THE FOLLOWING SAFETY INSTRUCTIONS:**

- Check all clamps, bolts, lids, lock rings, and system accessories to ensure they are properly installed and secured before testing.
- **RELEASE ALL AIR** in the system before testing.
- Water pressure for test must **NOT EXCEED 35 PSI**.
- Water temperature for test must **NOT EXCEED 100°F (38°C)**.
- Limit test to 24 hours. After test, visually check system to be sure it is ready for operation.

Notice: These parameters apply to Jandy equipment only. For non-Jandy equipment, consult the equipment manufacturer.

⚠ WARNING

Chemical spills and fumes can weaken pool/spa equipment. Corrosion can cause filters and other equipment to fail, resulting in severe injury or property damage. Do not store pool chemicals near your equipment.

CAUTION

Do not start pump dry! Running the pump dry for any length of time will cause severe damage and will void the warranty.

CAUTION

- This pump is for use with permanently installed pools and may also be used with hot tubs and spas, if so marked. Do not use with storable pools. A permanently installed pool is constructed in or on the ground or in a building, such that it cannot be readily disassembled for storage. A storable pool is constructed so that it may be readily disassembled for storage and reassembled to its original integrity.
- Do not install beneath the skirt of a hot tub. The pump requires adequate ventilation to maintain air temperature at less than the maximum ambient temperature rating listed on the motor rating plate.
- For Canadian installation, this pump carries a Type 3R enclosure rating and therefore is not intended for installation in areas subjected to windblown dust.

SAVE THESE INSTRUCTIONS

1.2 Pool Pump Suction Entrapment Prevention Guidelines

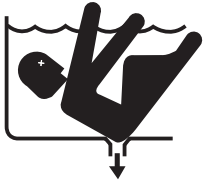

⚠ WARNING

SUCTION HAZARD. Can cause serious injury or death. Do not use this pump for wading pools, shallow pools, or spas containing bottom drains, unless pump is connected to at least two (2) functioning suction outlets.

⚠ WARNING

Pump suction is hazardous and can trap and drown or disembowel bathers. Do not use or operate swimming pools, spas, or hot tubs if a suction outlet cover is missing, broken, or loose.

The following guidelines provide information for pump installation that minimizes risk of injury to users of pools, spas, and hot tubs:

Entrapment Protection - The pump suction system must provide protection against the hazards of suction entrapment.

Suction Outlet Covers - All suction outlets must have correctly installed, screw-fastened covers in place. All suction outlet (drain) covers must be maintained. Drain covers must be listed/certified to the latest published edition of ANSI/ASME A112.19.8. They must be replaced if cracked, broken, or missing.

Number of Suction Outlets Per Pump - Provide at least two (2) hydraulically-balanced main drains, with covers, as suction outlets for each circulating pump suction line. The centers of the main drains (suction outlets) on any one (1) suction line must be at least three (3) feet apart, center to center. See Figure 1 on page 7.

The system **must** be built to include at least two (2) suction outlets (drains) connected to the pump whenever the pump is running. However, if two (2) main drains run into a single suction line, the single suction line may be equipped with a valve that will shut off both main drains from the pump. The system shall be constructed such that it shall not allow for separate or independent shutoff or isolation of each drain. See Figure 1 on page 7.

More than one (1) pump can be connected to a single suction line as long as the requirements above are met.

Water Velocity - The maximum water velocity through the suction fitting or cover for any suction outlet must be 1.5 feet per second, unless the outlet complies with the latest published edition of ANSI/ASME A112.19.8, the standard for *Suction Fittings For Use in Swimming and Wading Pools, Spas, Hot Tubs, and Whirlpool Bathtub Applications*. In any case, do not exceed the suction fitting's maximum designed flow rate.

If 100% of the pump's flow comes from the main drain system, the maximum water velocity in the pump suction hydraulic system must be six (6) feet per second or less, even if one (1) main drain (suction outlet) is completely blocked. The flow through the remaining main drain(s) must comply with the latest published edition of ANSI/ASME A112.19.8, the standard for *Suction Fittings For Use in Swimming and Wading Pools, Spas, Hot Tubs, and Whirlpool Bathtub Applications*.

Testing and Certification - Suction outlet covers must have been tested by a nationally recognized testing laboratory and found to comply with the latest published edition of ANSI/ASME A112.19.8, the standard for *Suction Fittings For Use in Swimming and Wading Pools, Spas, Hot Tubs, and Whirlpool Bathtub Applications*.

Fittings - Fittings restrict flow; for best efficiency use fewest possible fittings (but at least two (2) suction outlets).

Avoid fittings that could cause an air trap.

Pool cleaner suction fittings must conform to applicable International Association of Plumbing and Mechanical Officials (IAPMO) standards.

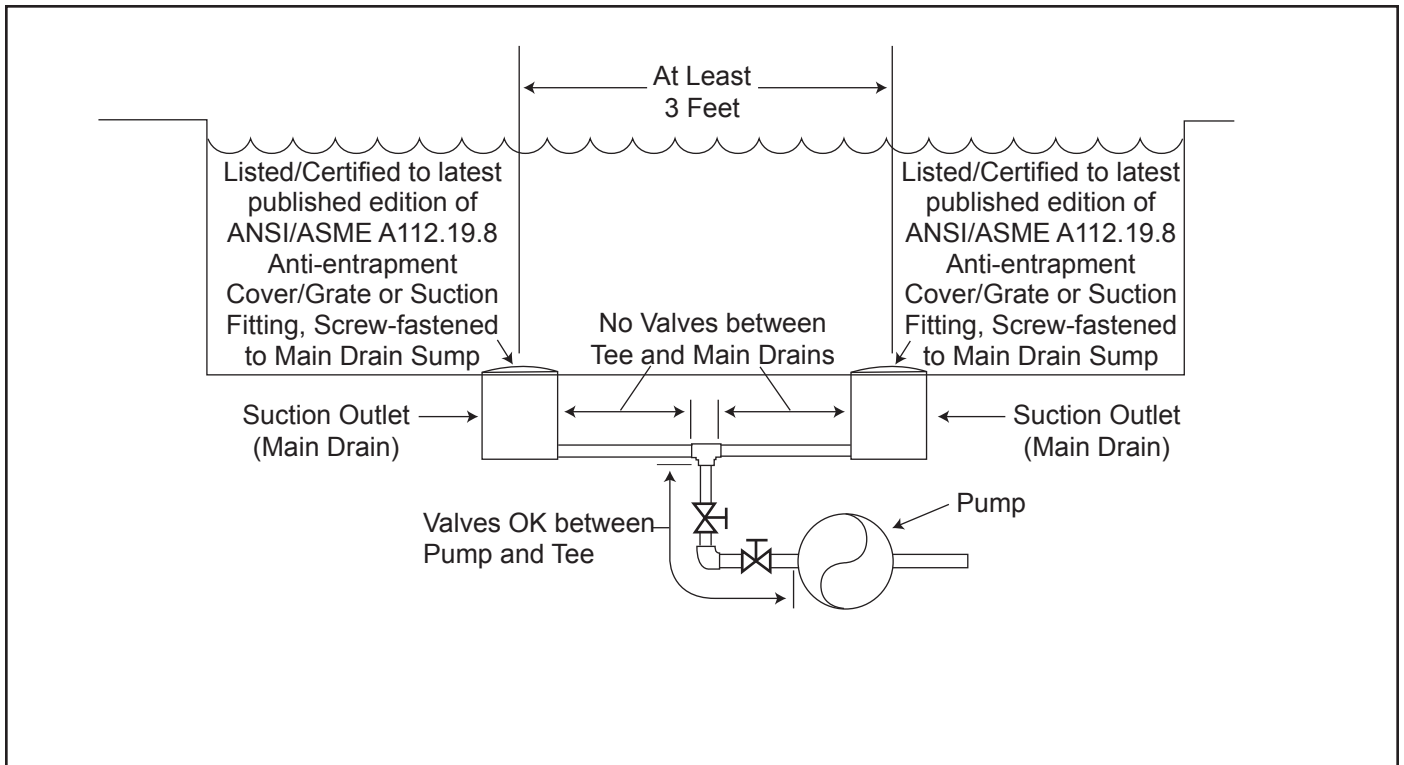

Figure 1. Number of Suction Outlets Per Pump

Section 2. General Description

2.1 Introduction

This manual contains information for the proper installation, operation, and maintenance of Jandy ePump Series variable-speed pumps. Procedures in this manual must be followed exactly. To obtain additional copies of this manual, contact Jandy Customer Service at 800.822.7933. For address information, see the back cover of this manual.

2.2 Description

The ePump is a variable-speed pump that can be run from 600 RPM to 3450 RPM. When connected to the Jandy ePump controller, up to eight (8) speed settings may be programmed and recalled. This allows you to select the most appropriate speed for your application. Even more versatile programming is possible when you use a Jandy AquaLink® RS controller.

Jandy ePump Series Pumps are designed to meet the needs of today's more hydraulically demanding pool equipment. The pump housing, backplate, diffuser, impeller, and hair and lint pot (pump debris filter basket) are all made from high quality thermoplastic materials. These materials were chosen for their strength and corrosion resistance.

The pump is driven by an electric motor directly attached to the pump impeller. As the electric motor turns, it causes the impeller to turn, which forces water to flow through the pump. The water flows through the pump inlet and then into the filter basket. The basket assembly pre-strains/traps large particles. The water then enters the center of the pump housing, flows through the impeller into the diffuser, and flows out the pump discharge port.

Section 3. Installation Information

3.1 Plumbing

3.1.1 Preparation Information

1. Upon receipt of the pump, check the carton for damage. Open the carton and check the pump for concealed damage, such as cracks, dents or a bent base. If damage is found, contact the shipper or distributor where the pump was purchased.
2. Inspect the contents of the carton and verify that all parts are included. See *Section 7.1, Replacement Parts List and Exploded View*.

3.1.2 Pump Location

CAUTION

For Canadian installation, this pump carries a Type 3R enclosure rating and therefore is not intended for installation in areas subjected to windblown dust.

1. Jandy recommends installing the pump within one (1) foot above water level. The pump should not be elevated more than a few feet above the water level of the pool. A check valve is recommended on the suction line to the pump.

⚠ WARNING

Some Safety Vacuum Release System (SVRS) devices are not compatible with the installation of check valves. If the pool has an SVRS device, be sure to confirm that it will continue to safely operate when any check valves are installed.

NOTE To achieve better self-priming, install the pump as close as possible to the water level of the pool.

2. If the pump is located below water level, isolation valves must be installed on both the suction and return lines to prevent back flow of pool water during any routine or required servicing.
3. The pump and other circulation equipment must be located more than five (5) feet from the water. Choose a location that will minimize turns in the piping.

NOTE In Canada, the pump must be located a minimum of three (3) meters (approximately 10 feet) from the water (CSA C22.1).

4. The pump must be placed on a solid foundation that will not vibrate. To further reduce the possibility of vibration noise, bolt the pump to the foundation, or place it on a rubber mat.

NOTE Zodiac Pool Systems, Inc. recommends bolting the pump directly to the foundation.

5. The pump foundation must have adequate drainage to prevent the motor from getting wet. Protect the pump from the rain and sun.
6. Proper ventilation is required for the pump to operate normally. All motors generate heat that must be removed by providing proper ventilation.

7. Provide access for future services by leaving a clear area around the pump. Allow plenty of space above the pump to remove the lid and basket for cleaning.
8. If the equipment is in a potentially dark area, provide adequate lighting.

3.1.3 Pipe Sizing

NOTE All HP ratings given in this section apply to full-rated pumps.

3.1.3.1 Suction Pipe

When the pump is located up to 50 feet from the pool, the recommended minimum pipe size for the suction side of the pump is 2" for .75 to 1.5 HP*. For 2.0 HP* pumps, the recommended pipe size is 2 ½". For 3.0 HP* pumps, the recommended pipe size is 3".

* HP refers to full rated pumps.

3.1.3.2 Discharge Pipe

When the pump is located up to 50 feet from the pool, the recommended minimum pipe size for the discharge side of the pump is 2" for .75 to 1.5 HP*. For 2.0 HP* pumps, the recommended pipe size is 2½". For 3.0 HP* pumps, the recommended pipe size is 3".

* HP refers to full rated pumps.

NOTE All pipe sizes are able to withstand the pressures the pump will deliver, but not necessarily the flow. If the pipe is too small for the pump, or is elevated above water, the maximum gallons per minute (GPM) may not be delivered. If this happens, the pump will develop a pocket of air (cavitation) that makes noise. This may shorten the life of the pump.

3.1.3.3 Installation Recommendations

1. If the pump is located below water level, isolation valves must be installed on both sides of the pump to prevent the back flow of pool water during any routine or required servicing.
2. To help prevent difficulty in priming, install the suction pipe without high points (above inlet of pump - inverted "U"s, commonly referred to in plumbing as an airlock) that can trap air. For installations of equipment up to 100 feet from the water, refer to Table 1, the pipe sizing chart. For installations of equipment more than 100 feet from the water, the recommended pipe size must be increased to the next size.

Table 1. Pipe Sizing Chart for Schedule 40 PVC

Pipe Size	Maximum Flow Suction (8 feet per second)	Maximum Flow Discharge (10 feet per second)
1½"	50 GPM (189 LPM)	65 GPM (246 LPM)
2"	85 GPM (322 LPM)	105 GPM (397 LPM)
2½"	120 GPM (454 LPM)	149 GPM (564 LPM)
3"	184 GPM (697 LPM)	230 GPM (871 LPM)

3. ePump Series Pumps come equipped with unions on both the suction and discharge ports. This feature simplifies installation and service and eliminates the possibility of leaks at threaded adapters.
4. The ePump Series Pump must be connected to at least two (2) hydraulically-balanced main drains (suction outlets) for each pool pump suction line. Each drain must be provided with covers that are listed or certified to the latest published edition of ANSI/ASME A112.19.8. The suction outlets of the main drains must be at least three (3) feet apart or at different planes. The suction outlets can be a drain and skimmer, two (2) drains, two (2) skimmers, or a skimmer with an equalizer line installed. For additional details and guidelines, refer to ANSI/SPSP 7, the standard for Suction Entrapment Avoidance in Swimming Pools, Wading Pools, Spas, Hot Tubs, and Catch Basins. Check the local codes for proper installation requirements. Applicable local codes will take precedence over other codes.

NOTE To prevent entrapment, the system must be built so it cannot operate with the pump drawing water from only one (1) main drain. At least two (2) main drains must be connected to the pump when it is in operation. However, if two (2) main drains run into a single suction line, the single suction line may be equipped with a valve that will shut off both main drains from the pump.

5. The piping must be well supported and not forced together where it will experience constant stress.
6. Always use properly sized valves. Jandy Diverter Valves and Jandy Ball Valves typically have the best flow capabilities.
7. Use the fewest fittings possible. Each additional fitting has the effect of moving the equipment farther away from the water.

NOTE If more than ten suction fittings are needed, the pipe size must be increased.

8. Every new installation must be pressure tested according to local codes.

3.2 Electrical Installation

3.2.1 Voltage Checks

The correct voltage, as specified on the pump data plate, is necessary for proper performance and long motor life. Incorrect voltage will decrease the pump’s ability to perform and could cause overheating, reduce the motor life, and result in higher electric bills.

It is the responsibility of the electrical installer to provide data plate operating voltage to the pump by ensuring proper circuit sizes and wire sizes for this specific application.

CAUTION

Failure to provide data plate voltage (within 10%) during operation will cause the motor to overheat and void the warranty.

3.2.2 Bonding and Grounding

1. The motor frame must be grounded to a reliable grounding point using a solid copper conductor, No. 8 AWG or larger. In Canada, No. 6 AWG or larger must be used. If the pump is installed within five (5) feet of the inside walls of the swimming pool, spa, or hot tub, the motor frame must be bonded to all metal parts of the swimming pool, spa, or hot tub structure and to all electrical equipment, metal conduit, and metal piping within 5 feet of the inside walls of the swimming pool, spa, or hot tub.
2. Bond the motor using the provided external lug.

⚠ WARNING

Always disconnect the power source before working on a motor or its connected load.

⚠ WARNING

In order to avoid the risk of property damage, severe personal injury, and/or death, make sure that the control switch, time clock, or control system is installed in an accessible location, so that in the event of an equipment failure or a loose plumbing fitting, the equipment can be easily turned off.

CAUTION

The pump must be permanently connected to a dedicated electrical circuit. No other equipment, lights, appliances, or outlets may be connected to the pump circuit, with the exception of devices that may be required to operate simultaneously with the pump, such as a chlorinating device or heater.

3.2.3 Electrical Wiring

1. The pump motor must be securely and adequately grounded using the green screw provided. Ground before attempting to connect to an electrical power supply. Do not ground to a gas supply line.
2. Wire size must be adequate to minimize voltage drop during the start-up and operation of the pump. See Table 2 for suggested wire sizes.
3. Insulate all connections carefully to prevent grounding or short-circuits. Sharp edges on terminals require extra protection. To prevent the wire nuts from loosening, tape them using a suitable, listed (UL, ETL, CSA) electrical insulating tape. For safety, and to prevent entry of contaminants, reinstall all conduit and terminal box covers. Do not force connections into the conduit box.
4. Note the LED on the top of the electronics drive enclosure (to the lower left of the ePump label). The LED is lit whenever power is present at the motor, regardless of whether the motor is running or not.

NOTE Since the pump is operated by either an ePump controller (JEP-R), an AquaLink® RS controller, or an AquaLink® Pool Digital Assistant (PDA), the pump will not be turned on until it is turned on with one of these controllers.

Table 2. Recommended Wire Sizes for ePumps

RECOMMENDED MINIMUM WIRE SIZE FOR ePUMP SERIES PUMPS*					
Distance from Sub-panel		0-50 Feet	50-100 Feet	100 - 150 Feet	150 - 200 Feet
Model	Branch Fuse AMPS Class:CC, G, H, J, K, RK, or T 230 VAC	Voltage 208-230 VAC	Voltage 208-230 VAC	Voltage 208-230 VAC	Voltage 208-230 VAC
JEP2.0	20A	12	10	8	6
JEP1.5	20A	12	10	8	6

*Assumes three (3) copper conductors in a buried conduit and 3% maximum voltage loss in branch circuit. All National Electrical Code (NEC) and local codes must be followed. Table shows minimum wire size and branch fuse recommendations for typical installation per NEC.

3.2.4 Installing the Controller

The ePump can be operated by one of three (3) controllers: the ePump controller (JEP-R), the AquaLink® RS controller (Rev O or later), or the AquaLink® PDA (Rev 4.0 or later).

The ePump communicates with the controllers via a four-wire RS-485 interface.

To install the ePump controller:

NOTE The ePump controller part no. is JEP-R.

1. Remove power from the ePump by disconnecting the high voltage lines or by opening any breaker to which the ePump power is connected.

⚠ WARNING

ELECTRICAL SHOCK HAZARD

Turn off all switches and the main breaker in the ePump electrical circuit before starting the procedure. Failure to comply may cause a shock hazard, resulting in severe personal injury or death.

2. Remove the cover of the ePump junction box and feed the RS-485 cable into the fitting.
3. Unplug the RS-485 connector from the ePump.
4. Attach the four (4) wires in the RS-485 cable to the RS-485 connector. Match the wire colors with the positions on the connector: 1- red, 2- black, 3- yellow, and 4- green. See Figure 2.
5. Insert the RS-485 connector back into the ePump.

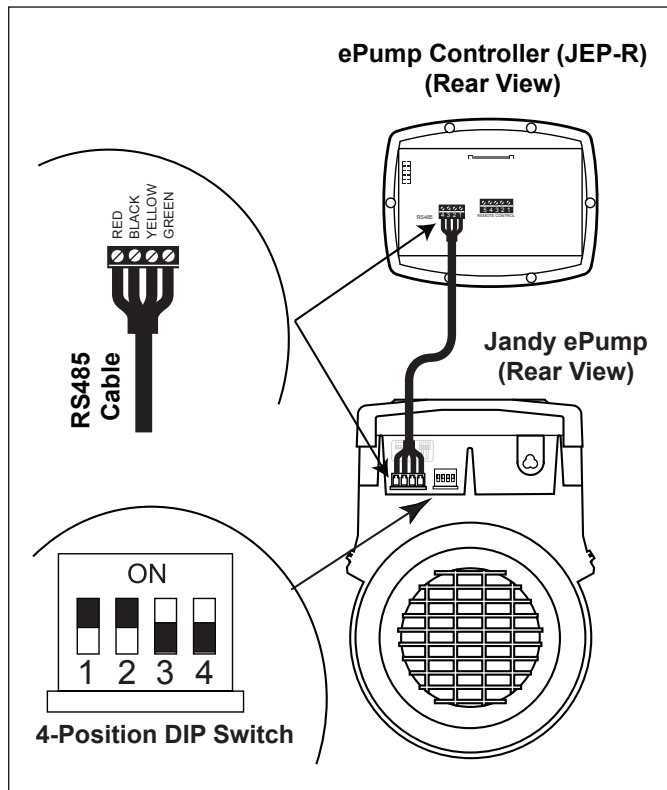

Figure 2. Wiring ePump Controller (JEP-R) to ePump

6. Slide dip switches 1 and 2 up, so they are in the ON position, and slide switches 3 and 4 down, so they are in the OFF position. See Figure 2.
7. Connect the other end of the cable to the controller. Match the colors of the wires with the appropriate connector positions, as described in Step 4.
8. Restore power to the ePump and verify the operation of the controller.
9. Refer to the ePump Controller Owner's Manual, H0311200, to operate the pump.

To install an AquaLink® RS controller (Rev O or later) or an AquaLink® PDA (Rev 4.0 or later):

1. Remove power from the ePump by disconnecting the high voltage lines or by opening any breaker to which the ePump power is connected.

⚠ WARNING

ELECTRICAL SHOCK HAZARD

Turn off all switches and the main breaker in the ePump electrical circuit before starting the procedure. Failure to comply may cause a shock hazard, resulting in severe personal injury or death.

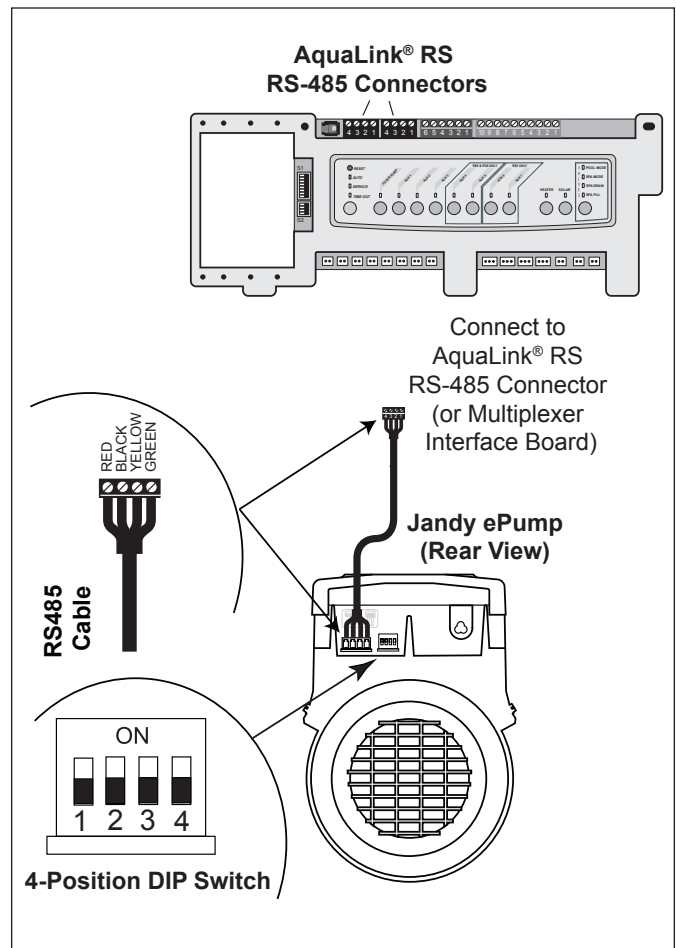

Figure 3. Wiring AquaLink® RS Controller or AquaLink® PDA to ePump

2. Remove the cover of the ePump junction box and feed the RS-485 cable into the fitting.
3. Unplug the RS-485 connector from the ePump and attach the four (4) wires in the RS-485 cable to the RS-485 connector. Match the wire colors with the connector positions as follows: 1-red, 2-black, 3-yellow, and 4-green. See Figure 3.
5. Insert the RS-485 connector back into the ePump.
6. Slide dip switches 1 and 2 down, so they are in the OFF position. See Figure 3.
7. Select the desired address(es) for the ePump(s) by setting dip switches 3 and/or 4, as shown in *Section 3.3, ePump Dip Switch Settings*.
8. Connect the other end of the cable to an RS-485 connector on the AquaLink® RS (or multiplexer interface board), matching wire colors with connector positions, as described in Step 3.
9. Restore power to the ePump and verify the operation of the controller.
10. Refer to the appropriate manual to operate the pump: AquaLink® RS Owner's Manual, 6593, or AquaLink® PDA Owner's Manual, H0572300.

3.3 ePump Dip Switch Settings

As shown in Figures 2 and 3, the 4-position dip switch is located at the rear of the ePump. This dip switch serves two (2) functions: it selects the pump address, and it determines what type of controller will be used with the pump. The tables below show the dip switch settings.

Switch 1	Switch 2	Controller
OFF	OFF	AquaLink® RS or AquaLink® PDA
OFF	ON	AquaLink® RS or AquaLink® PDA
ON	OFF	AquaLink® RS or AquaLink® PDA
ON	ON	ePump Controller (JEP-R)

Switch 3	Switch 4	Pump Address
OFF	OFF	PUMP 1
OFF	ON	PUMP 2
ON	OFF	PUMP 3
ON	ON	PUMP 4

3.4 Pressure Testing

All Jandy model ePumps come with an additional disposable o-ring for pressure testing. This is the blue pressure test o-ring. See Figures 4 and 5.

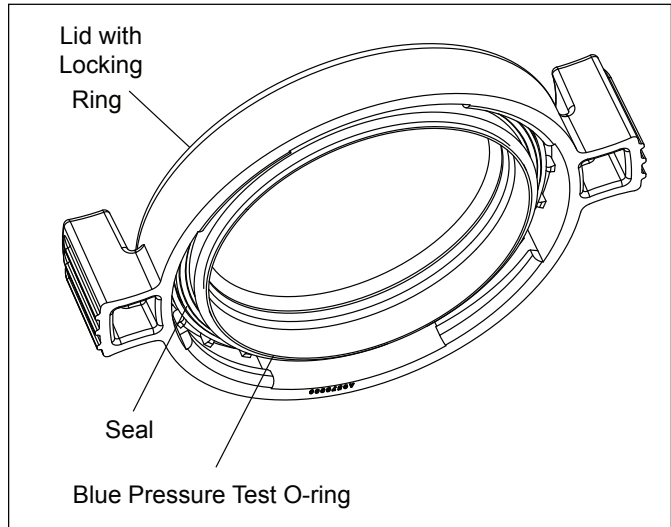

Figure 4. Blue Pressure Test O-ring in Lid Assembly

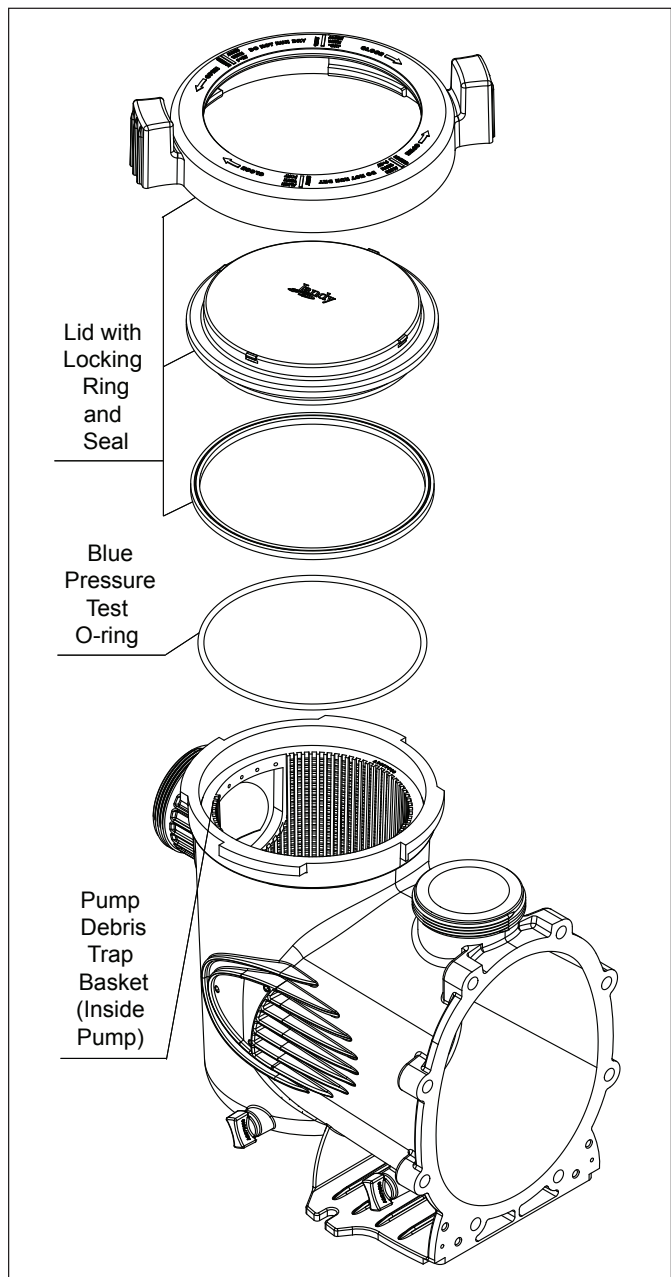

Figure 5. Exploded View of Pump

CAUTION

Do not open the pump lid before pressure testing, because the blue pressure test o-ring may fall out. If this happens, you will need to replace it.

If you have not opened the pump lid, skip to *Section 3.5, Conducting Pressure Test*.

3.4.1 Replace Blue Pressure Test O-ring if Necessary

If you open the pump lid before conducting the pressure test, the blue o-ring will probably fall out. If this happens, you will need to install it on the lid again before conducting pressure testing.

There is a risk of damage to the blue o-ring during re-installation. If you damage it when trying to re-install it, you will need to order a new blue pressure test o-ring before you begin conducting the pressure test.

These instructions describe the proper procedures for replacing, using, and disposing of the blue o-ring.

These instructions must be followed exactly. Read through the instructions completely before starting the procedure.

3.4.1.1 Remove Pump Lid

1. Make sure that the pump is turned off.
2. Make sure that the switch to the circuit breaker that powers the pump motor is turned off.

⚠ WARNING

ELECTRICAL SHOCK HAZARD

Turn off the pump and the main breaker in the pump electrical circuit before starting the procedure. Failure to comply may cause a shock hazard, resulting in severe personal injury or death.

⚠ WARNING

ELECTRICAL SHOCK HAZARD

Due to the potential risk of fire, electric shock, or injuries to persons, Jandy Pumps must be installed in accordance with the National Electrical Code (NEC), all local electrical and safety codes, and the occupational Safety and Health Act (OSHA). Copies of the NEC may be ordered from the National Protection Association, 470 Atlantic Ave., Boston, MA 02210, or from your local government inspection agency.

In Canada, Jandy Pumps must be installed in accordance with the Canadian Electrical Code (CEC).

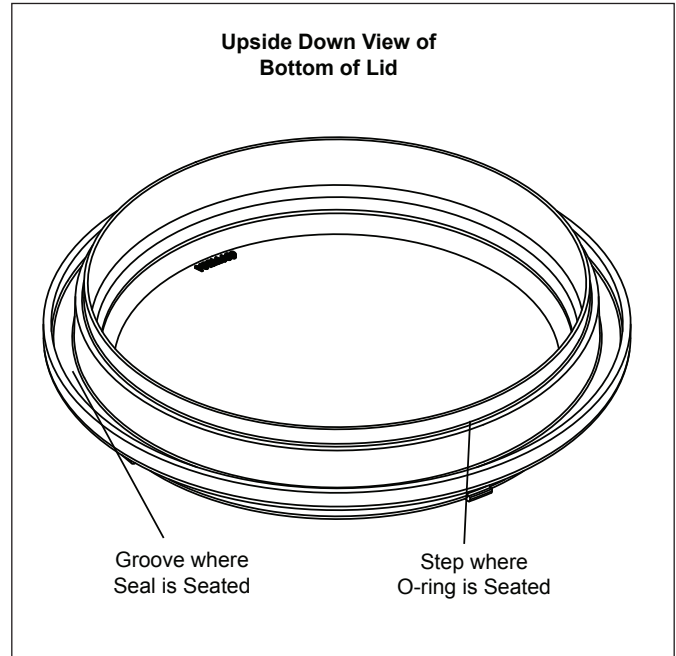

Figure 6. Placement of Blue Pressure Test O-ring

3. Make sure all necessary isolation valves are closed to prevent pool water from reaching the pump.
4. Following the markings on the locking ring, turn the ring counter-clockwise until the 'START' markings align with the ports.
5. Carefully remove the lid with locking ring.

3.4.1.2 Replace Blue O-ring

1. Turn the lid with locking ring upside down and place it on a stable surface.
2. Place the blue o-ring on the step located ¼" from the bottom of the lid. See Figure 6.
3. Make sure that the o-ring is properly seated. It helps to "place" the o-ring on the step rather than to "roll" it on. That prevents it from rolling off.

NOTE The blue o-ring sits approximately ¼" away from the seal. See Figure 6.

4. Carefully install the lid, making sure that the blue pressure test o-ring sits in the housing without "binding" or "rolling" off.
5. Following the markings on the locking ring, align 'START' markings with the ports and turn clockwise until 'LOCKED' markings align with the ports. **Do not tighten past the 'LOCKED' marking.**

3.5 Conduct Pressure Test

WARNING

When pressure testing a system with water, air is often trapped in the system during the filling process. This air will compress when the system is pressurized. Should the system fail, this trapped air can propel debris at a high speed and cause injury. Every effort to remove trapped air must be taken, including opening the bleed valve on the filter and loosening the pump basket lid while filling the pump.

WARNING

Trapped air in the system can cause the filter lid to be blown off, which can result in death, serious injury, or property damage. Be sure all air is properly purged out of the system before operating. **DO NOT USE COMPRESSED AIR TO PRESSURE TEST OR CHECK FOR LEAKS.**

WARNING

Do not pressure test above 35 PSI. Pressure testing must be done by a trained pool professional. Circulation equipment that is not tested properly might fail, which could result in severe injury or property damage.

WARNING

When pressure testing the system with water, it is very important to make sure that the pump basket lid is completely secure.

1. Fill the system with water, using care to eliminate trapped air.
2. Pressurize the system with water to no more than **35 PSI**.
3. Close the valve to trap pressurized water in the system.
4. Observe the system for leaks and/or pressure decay.
5. If there are lid leaks, repeat Steps 1-3. For technical support, call 800.822.7933.
6. After successfully completing the test, discard the blue pressure test o-ring.

Section 4. Operation

4.1 Start-up

CAUTION

Never run the pump without water. Running the pump “dry” for any length of time can cause severe damage to both the pump and motor and will void the warranty.

If this is a new pool installation, make sure all piping is clear of construction debris and has been properly pressure tested. The filter should be checked for proper installation, verifying that all connections and clamps are secure according to the manufacturer’s recommendations.

WARNING

To avoid risk of property damage, severe personal injury or death, verify that all power is turned off before starting this procedure.

1. Release all pressure from the system and open the filter pressure release valve.
2. Depending on the location of the pump, do one of the following:
 - If the pump is located below the water level of the pool, open the filter pressure release valve to prime the pump with water.
 - If the pump is located above the water level of the pool, remove the lid and fill the basket with water before starting the pump.
3. Prior to replacing the lid, check for debris around the lid o-ring seat. Debris around the lid o-ring seat will cause air to leak into the system and will make it difficult to prime the pump.
4. **Hand-tighten** the lid to make an air tight seal. Do not use any tools to tighten the lid: **hand-tighten only**. Make sure all valves are open and the unions are tight.
5. Restore power to the pump. Then turn on the pump by following the instructions in the appropriate manual: ePump Controller Owner’s manual, H0311200, AquaLink® RS Owner’s Manual, 6593, or AquaLink® PDA Owner’s Manual, H0572300.
6. Once all the air has left the filter, close the pressure release valve.

7. The pump should prime. The time it takes to prime will depend on the elevation and length of pipe used on the suction supply pipe. See *Section 3.1.3.3, Installation Recommendations*, for proper elevation and pipe size.
8. If the pump does not prime and all the instructions to this point have been followed, check for a suction leak. If there is no leak, repeat Steps 2 through 7.
9. For technical assistance, call Jandy Technical Support at 800.822.7933.
8. Verify that all valves have been returned to the proper position for normal operation.
9. Open the pressure release valve on the filter, and make sure it is clean and ready for operation.
10. Turn on the power to the pump. Once all the air has been evacuated from the filter, close the pressure release valve.

Section 5. Service and Maintenance

5.1 Routine Maintenance

Inspect the pump debris tray basket for debris by looking through the clear pump lid. Remove any debris, because as debris accumulates, it will begin to block the flow of water through the pump. Keep the basket clean to improve the performance of the pump.

1. Turn off the power to the pump. If the pump is located below the water level, close the isolation valves on the suction and discharge sides of the pump to prevent backflow of water.
2. Turn the lid's locking ring counter-clockwise until 'START' aligns with the ports. Carefully remove the lid. (You may use a tool for leverage.)

CAUTION

A misaligned basket will cause the lid to be improperly seated, allowing an air leak, which could result in pump damage.

3. Lift the basket out of the pump.
4. Dispose of the debris and thoroughly clean the basket, making sure all the holes are open. Using a garden hose, spray the basket from the outside to help clear the holes. Remove any remaining debris by hand.
5. Replace the basket in the pump by aligning the opening with the suction pipe. If aligned properly, the basket will drop easily into place. **Do not force it into place.**
6. Remove the lid seal and remove debris around the lid seal seat, as this can allow air to leak into the system. Clean the lid seal and place it on the lid.
7. Replace the lid with locking ring. **Hand-tighten** the lid to make an air-tight seal. Do not use any tools to tighten the lid: **hand-tighten only.**

5.2 Winterizing the Pump

CAUTION

The pump **must** be protected when freezing temperatures are expected. Allowing the pump to freeze will cause severe damage and void the warranty.

CAUTION

Do not use antifreeze solutions in the pool, spa, or hot tub systems! Antifreeze is highly toxic and may damage the circulation system. The only exception to this is Propylene Glycol. For more information, see your local pool/spa supply store or contact a qualified swimming pool service company.

1. Drain **all** water from the pump, system equipment, and piping.
2. Remove the two (2) drain plugs. Store the drain plugs in a safe location and reinstall them when the cold weather season is over. **Do not lose the o-rings.**
3. Keep the motor covered and dry. Do not cover the pump with plastic, because this will create condensation that will damage the pump.

NOTE Zodiac Pool Systems, Inc. recommends having a qualified service technician or electrician properly disconnect the electrical wiring at the switch or junction box. Once the power is removed, loosen the two (2) unions and store the pump indoors. For safety, and to prevent entry of contaminants, reinstall all conduit and terminal box covers.

4. When the system is reopened for operation, have a qualified technician or electrician make sure all piping, valves, wiring and equipment are in accordance with the manufacturer's recommendations. Pay close attention to the filter and electrical connections.
5. The pump must be primed prior to starting. Refer to *Section 4.1, Start-up*.

Section 6. Troubleshooting and Repair

Zodiac Pool Systems, Inc. strongly recommends that you call a qualified service technician to perform any repairs on the filter/pump system. To locate a qualified technician, check your local yellow pages or visit www.jandy.com and click on “Product Support.”

6.1 Troubleshooting

Symptom	Possible Cause/Solution
The cleaning/circulating system is not operating correctly.	<p>Verify that skimmer baskets, pump basket and other screens are clean. Clean as necessary.</p> <p>Check filter and clean as necessary.</p> <p>Check valve positions. Adjust as necessary.</p> <p>NOTE Multiple pieces of equipment operating at one time (for example, waterfalls, spa jets, and surface returns) will affect the proper operation of the cleaning system.</p> <p>Check the cleaning system manual to ensure that the system is adjusted according to the manufacturer's recommendations.</p>
Bubbles are present in the pump basket.	<p>Air is in the system. Check the pool or spa water level to ensure that it is at the proper level and air is not being drawn into the suction piping. If the water is at the normal level, turn off the pump. Turn the lid's locking ring counter-clockwise until 'START' aligns with the ports. Remove the lid and check for debris around the lid seal seat OR improper installation of the lid seal, as either condition will allow air to leak into the system. Clean the lid seal and replace it on the lid. Replace the lid on the pump housing. Align 'START' with the ports and turn the locking ring clockwise until 'LOCKED' aligns with the ports. Hand-tighten the lid to make an air-tight seal. Do not use any tools to tighten the lid. Turn the pump back on.</p>
Air leaks are still present.	<p>Check the suction side piping union. While the pump is running, try to tighten the union. If this does not stop the air leak, turn off the pump. Loosen both unions and slide the pump out of the way. Remove, clean, and re-install both union o-rings.</p> <p>Reposition the pump next to the piping and secure the union nuts to the pump. With clean union o-rings, hand-tightening of the unions should create a seal. If the unions still do not seal, gently tighten with a large pair of tongue-and-groove pliers.</p> <p>Do not over-tighten.</p>
There is no air in the system, but the pressure is still low.	<p>It is possible that debris is caught in the pump impeller. The pump impeller moves the water, and the vanes in the impeller can become blocked with debris. See <i>Section 6.2, Service Technician Maintenance, 6.2.1, Blocked Impeller</i>, in this manual for more information.</p>
There is no debris blocking the impeller and the pressure is still low.	<p>The pump impeller and diffuser are showing signs of normal wear. Have a qualified service technician check the impeller and diffuser and replace as necessary.</p> <p>If the pump is part of a relatively new installation, it could be an electrical problem. Contact a qualified service technician. Have the technician check for loose electrical connections and check the voltage at the pump motor while it is in operation. The voltage must be within 10% of the motor's data plate rating. If the voltage is not within 10%, contact a qualified electrician and/or the local power service provider.</p> <p>Pump seal is leaking air. Have a qualified service technician replace the seal.</p>
The pump is leaking water between the motor and pump body.	<p>This is caused by a damaged or failed mechanical seal. Replace the seal. See <i>Section 6.2, Service Technician Maintenance, 6.2.3, Mechanical Seal Replacement</i>, in this manual.</p>
The pump gets hot and shuts off periodically.	<p>Make sure that there is adequate room around the motor to circulate air and keep the motor cool. Have a qualified electrician check for loose connections and check the voltage at the pump motor while it is in operation. The voltage must be within 10% of the motor's data plate rating. If the voltage is not within 10%, contact a qualified electrician and/or the local power service provider.</p>

Symptom	Possible Cause/Solution
<p>Pump will not start.</p>	<p>No power to pump.</p> <p>Make sure pump is properly connected to high voltage. LED on top of electronics enclosure should be illuminated. See <i>Section 3.2, Electrical Installation</i>, in this manual.</p>
	<p>Improper low-voltage wiring.</p> <p>Check low-voltage wiring between pump and controller. Correct if necessary. See <i>Section 3.2, Electrical Installation</i>, in this manual.</p>
	<p>Improper pump address setting.</p> <p>Make sure that ePump dip switches 3 and 4 are set properly for the installation. Both should be OFF for use with ePump controller or set to the proper address when connected to an AquaLink® RS controller or an AquaLink® PDA. See <i>Section 3.3, ePump Dip Switch Settings</i>, in this manual.</p>
	<p>Fault condition exists.</p> <p>View fault message on controller and correct fault before proceeding. If unsure how to correct fault, contact technical support at 800.822.7933.</p>
<p>ePump controller LCD is not displaying information or ePump LEDs are not illuminated.</p>	<p>Incorrect dip switch setting.</p> <p>Make sure ePump dip switches 1 and 2 are both ON. See <i>Section 3.3, ePump Dip Switch Settings</i>, in this manual.</p>
	<p>Improper low-voltage wiring.</p> <p>Check low-voltage wiring between pump and controller. Correct if necessary. See <i>Section 3.2, Electrical Installation</i>, in this manual.</p>
<p>Controller displays "Pump not connected".</p>	<p>Improper low-voltage wiring.</p> <p>Check low-voltage wiring between pump and controller. Correct if necessary. See <i>Section 3.2, Electrical Installation</i>, in this manual.</p>
	<p>Improper pump address set.</p> <p>Ensure ePump dip switches 3 and 4 are set properly for the installation. Both should be OFF for use with ePump controller or set to the proper address when connected to an AquaLink® RS controller or an AquaLink® PDA. See <i>Section 3.3, ePump Dip Switch Settings</i>, in this manual.</p>
<p>Fault message appears on controller display.</p>	<p>Fault condition exists.</p> <p>View fault message on controller and correct fault before proceeding. If unsure how to correct fault, contact technical support at 800.822.7933.</p>

6.2 Service Technician Maintenance

⚠ WARNING

This pump must be serviced by a professional service technician qualified in pool/spa installation. The following procedures must be followed exactly. Improper installation and/or operation can create dangerous electrical hazards, which can cause high voltages to run through the electrical system. This can cause property damage, serious personal injury, and/or death. Improper installation and/or operation will void the warranty.

6.2.1 Blocked Impeller

⚠ WARNING

Before servicing the pump, switch off the circuit breakers at the power source. Severe personal injury or death may occur if the pump starts while your hand is inside the pump.

1. Turn off the pump. Switch off the circuit breaker to the pump motor.
2. Remove the lid and basket.
3. Look inside the pump for debris. Remove any debris found inside.
4. Replace the basket and lid.
5. Switch on the circuit breaker to the pump motor.
6. Turn on the pump, and see if the problem is solved.
7. If the impeller is still blocked with debris and it is not possible to remove the debris using Steps 2 through 4, the pump will need to be disassembled in order to access the inlet and outlet of the impeller.

6.2.2 Impeller Removal and Replacement

⚠ WARNING

Before servicing the pump, switch off the circuit breakers at the power source. Severe personal injury or death may occur if the pump starts while your hand is inside the pump.

1. Turn off the pump. Switch off the circuit breaker to the pump motor. If you are not replacing the motor, do not disconnect the electrical wiring.

NOTE If you are replacing the motor, Zodiac Pool Systems, Inc. strongly recommends that a qualified service technician or electrician properly disconnect the electrical wiring at the pump motor.

2. Turn off any valves to prevent pool water from reaching the pump. Drain the water from the pump by loosening the unions or removing the drain plugs.
3. Using a 9/16" wrench, loosen the bolts connecting the pump body to the motor backplate. See Figure 7.

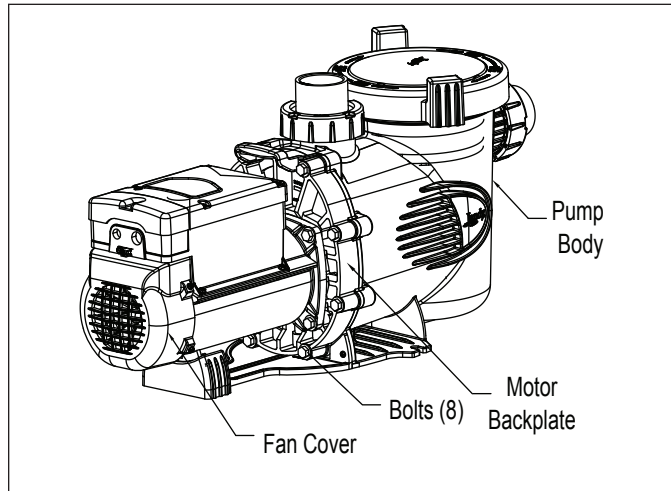

Figure 7. Remove the Pump Housing

4. Pull the motor and backplate out of the pump body. Remove the pump body o-ring. The impeller is connected to the motor shaft.
5. Using a No. 1 Phillips screwdriver, remove the two (2) screws holding the diffuser. (The diffuser is the cover over the impeller.) Then remove the diffuser. (See Figure 8.)
6. Access the inlet and outlet of the impeller and remove any debris.

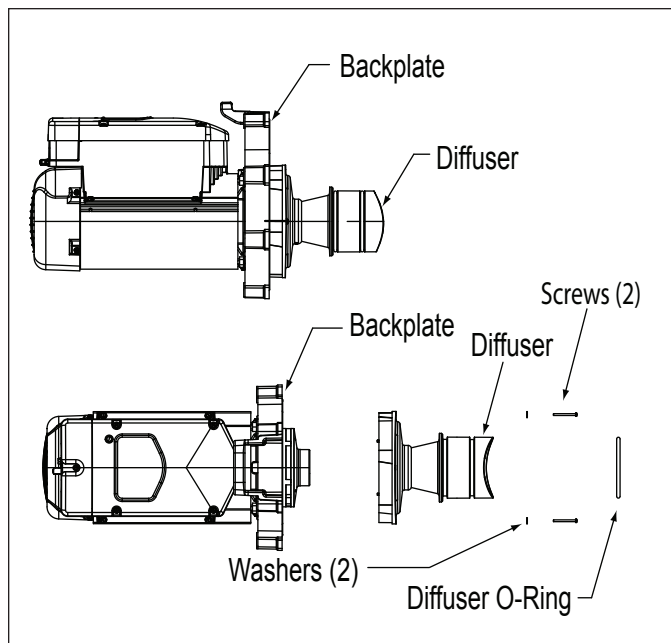

Figure 8. Remove the Diffuser

7. Remove the fan cover on the back of the motor by removing the screws. (See Figure 7.) The motor shaft and fan will be exposed.
8. Hold the exposed motor shaft with a ½" wide flat blade screw driver while removing the impeller center screw. Use a No. 3 Phillips screwdriver and turn the left-hand threaded screw clockwise to loosen it. See Figure 9.

- NOTE** Do not hold the fan to remove the impeller screw.
9. Hold the motor shaft with a ½" wide flat blade screw driver while unscrewing the impeller from the motor shaft with your hand. Turn the impeller counter-clockwise to unscrew it.
 10. Inspect the impeller and diffuser for signs of rubbing and/or damage.

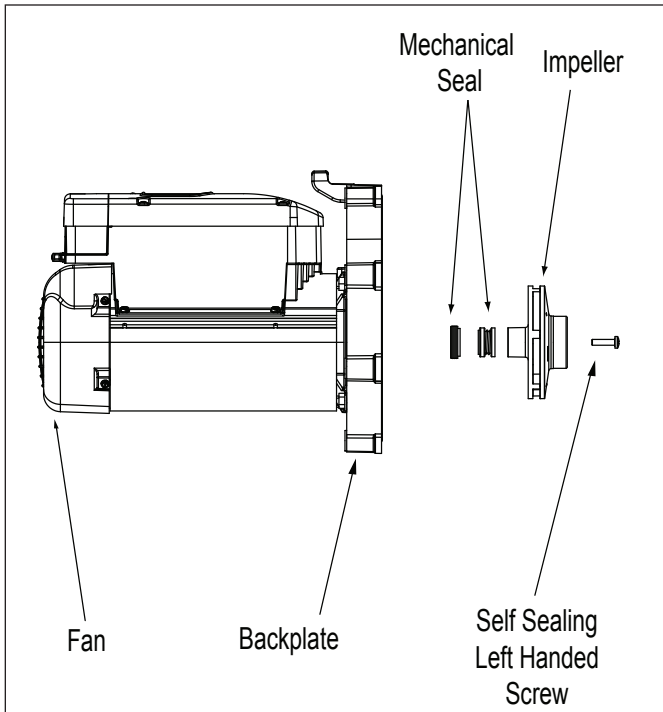

Figure 9. Remove the Impeller

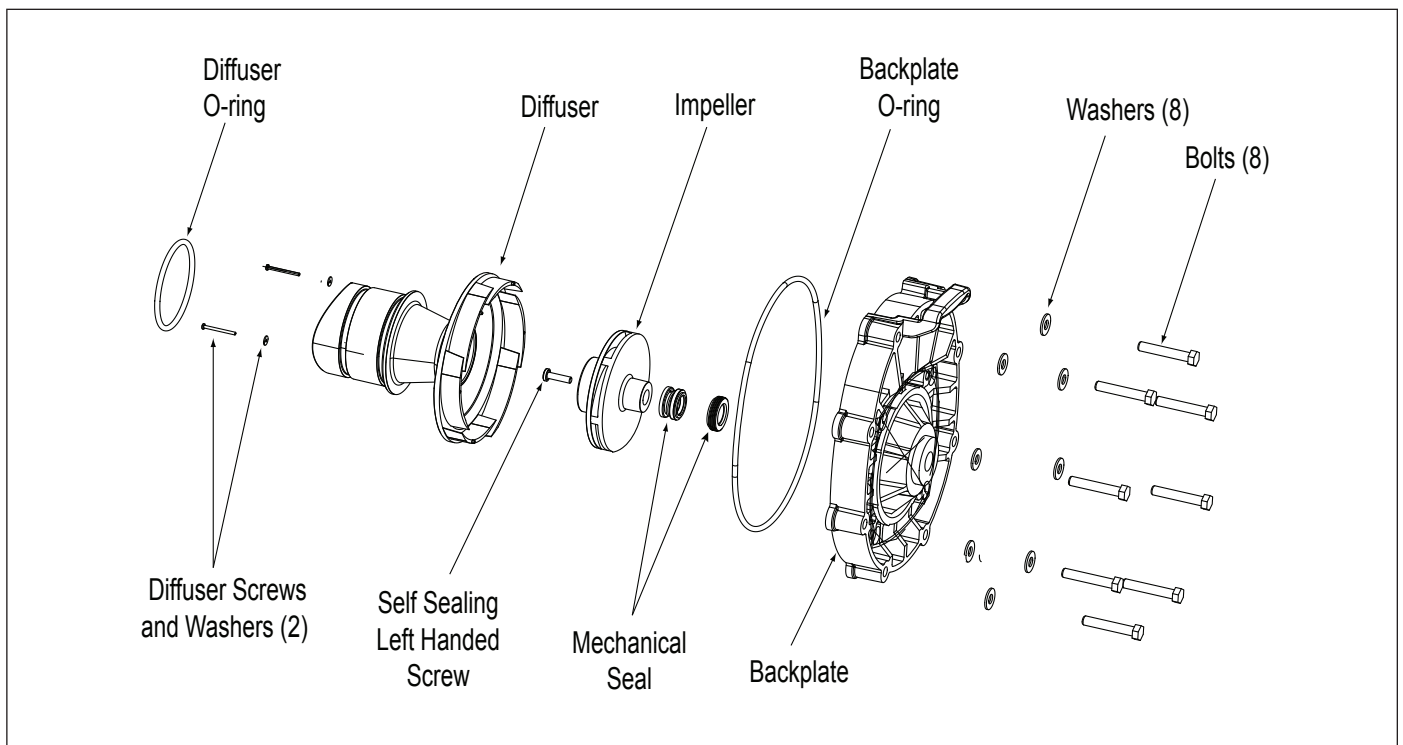

Figure 10. Diffuser and Impeller Exploded View

6.2.2.1 Impeller Reassembly

1. Press the new carbon face seal half (see Figure 11) on the motor shaft using a twisting motion. Make sure the carbon surface is facing toward the ceramic ring in the backplate.

CAUTION

Very Important! To prevent damage to the seal, grasp the lower portion of the seal (opposite the carbon face) when installing it

NOTE To assist assembly, use **only** water or soapy water as a lubricant. Any other lubricant will destroy the seal after a short period of time.

NOTE Be sure to keep the seal and mating parts clean.

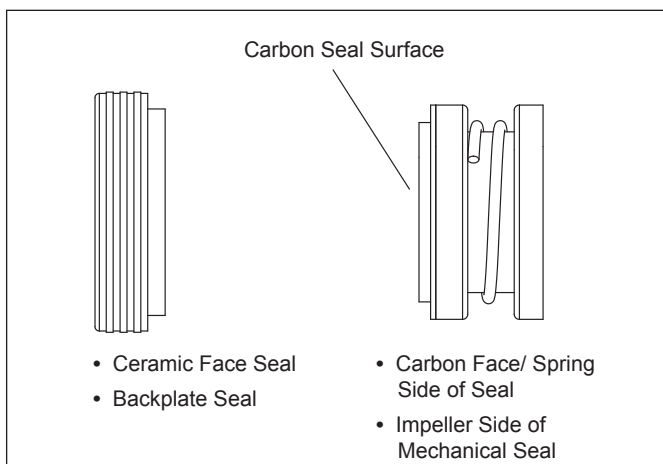

Figure 11. Mechanical Seal

2. While holding the motor shaft with a ½" wide flat blade screw driver, thread the impeller onto the motor shaft. Hand-tighten the impeller until it is secure. Install the impeller center screw into the center of the impeller. Turn the left-hand threaded screw counter-clockwise and tighten it, using a No. 3 Phillips screwdriver. **Do not overtighten.**
3. Replace the fan cover by replacing the screws.
4. Replace the motor shaft cover by inserting the cover tabs into the slots and rotating the cover 90° clockwise.
5. Replace the diffuser over the impeller, using care to insert alignment pins into the correct holes. The molded-in arrow must point toward the handle of the backplate.
6. Replace the two (2) small Phillips-head screws. Tighten the screws to draw the diffuser against the motor backplate.

7. To help prevent an airleak into the system, make sure the diffuser o-ring, o-ring groove, and o-ring seal area are clean and free of debris. If you removed the diffuser o-ring, make sure you install it into the groove you removed it from. (See Figure 12.) If grease is used to retain the o-ring, it **must** be silicone based. **Do not use petroleum-based grease.** It will destroy the o-ring.

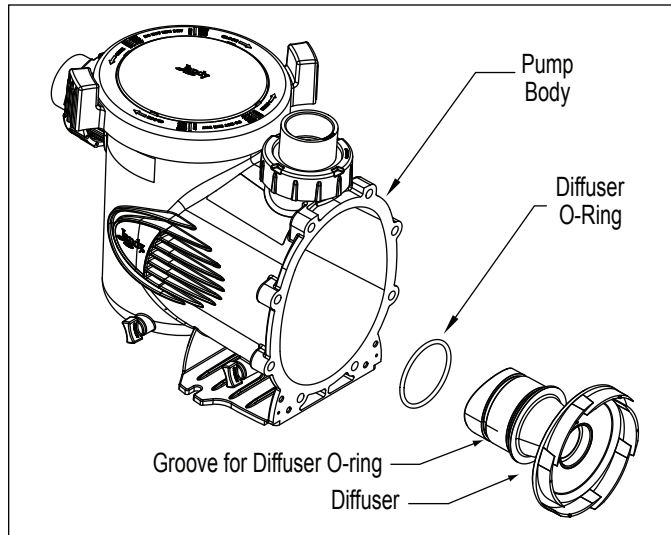

Figure 12. Pump Body and Diffuser Exploded View

8. Slide the diffuser into the mating hole in the pump body. While supporting the motor, start two (2) screws on opposite sides. (This will hold the motor in position while you start the other six (6) screws.)
9. Tighten the screws lightly in a crossing "X" pattern using a 9/16" wrench. Start with the inner (middle) four (4), then the outer (top and bottom) four (4) to draw the backplate to the body in an even manner. Once all the screws are snug, torque in the same order to 18 foot-pounds.
10. If the pump is located above the water level of the pool, remove the lid and fill the basket with water before starting the pump.
11. To help prevent an air leak into the system, remove any debris around the lid seal seat.
12. **Hand-tighten** the lid to make an air tight seal. **Do not use any tools to tighten the lid.**
13. Open the pressure release valve on the filter and make sure it is clean and ready for operation.
14. Switch on the circuit breaker to the pump motor.
15. Turn on the pump and check the system for normal operation.
16. Once all the air has left the filter, close the pressure release valve.

6.2.3 Mechanical Seal Replacement

NOTE This is a two-part replacement process. **The mechanical seal must be replaced as a set.**

NOTE Refer to Figure 13 for an illustration of the location of the mechanical seal and impeller.

CAUTION

Do not damage the ceramic or carbon surfaces of the seals. If the surfaces are damaged, leaks will occur.

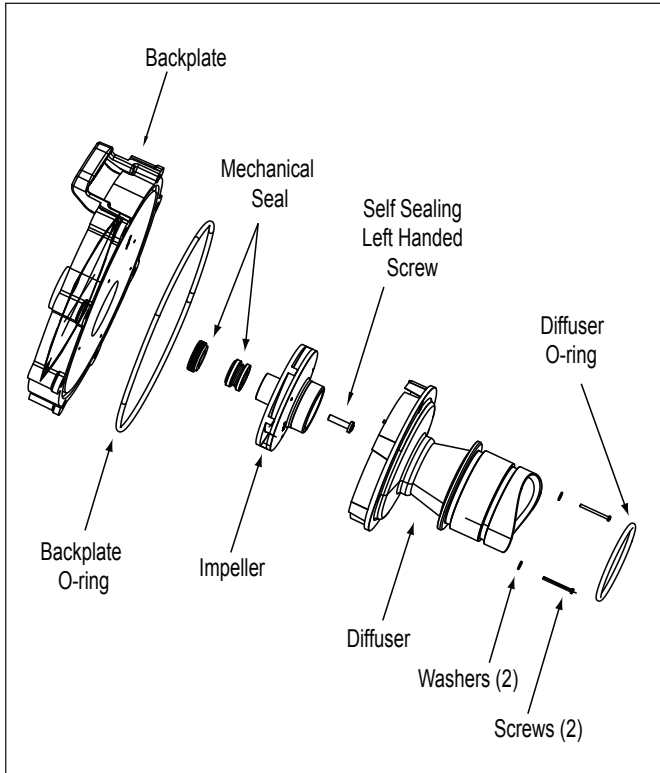

Figure 13. Backplate, Impeller, Diffuser, Mechanical Seal Exploded View

1. To access the mechanical seal, follow Steps 1 through 9 of *Section 6.2.2, Impeller Removal and Replacement*.
2. Remove the carbon face seal half from the motor shaft (See Figure 11). This is a spring-loaded seal. Grasp the portion of the seal closest to the impeller body and pull the seal off, using a twisting motion.
3. Remove the motor from the backplate, following the steps in *Section 6.2.5, Motor Replacement*.
4. Place the backplate o-ring side down and force the ceramic seal out using a screwdriver or drift.

5. Turn the backplate o-ring side up and insert the new ceramic seal side into the backplate. Use great care to press the seal in squarely with your fingers. The ceramic is easily damaged and must be pressed in using only your fingers or soft tools. Do not use any lubricant other than water or soapy water.
6. Install the backplate by following the relevant steps in *Section 6.2.2.1, Impeller Reassembly*.
7. Install the motor by following the steps in *Section 6.2.5, Motor Replacement*.

6.2.4 Variable Speed Drive Electronics Replacement

NOTE The Variable Speed Drive Electronics Unit and the motor are separate pieces of equipment and can be replaced independently of each other.

WARNING

To ensure continued safety and reliable operation, Zodiac Pool Systems, Inc. requires that you replace the Variable Speed Drive Electronics Unit with a unit that has the identical HP rating and service factor (Zodiac Pool Systems, Inc. approved unit only).

1. Turn off the electrical power to the pump motor using your controller. Switch off the circuit breaker to the pump motor.

WARNING

ELECTRICAL SHOCK HAZARD

Turn off all switches and the main breaker in the ePump electrical circuit before starting the procedure. Wait five (5) minutes after power is disconnected before opening motor. Do not proceed until the LED on top of the Drive Electronics is completely off. Failure to comply may cause a shock hazard, resulting in severe personal injury or death.

NOTE For instructions on operating the controller, refer to your controller manual: ePump Controller Owner's Manual, H0311200, AquaLink® RS Owner's Manual, 6593, or AquaLink® PDA Owner's Manual, H0572300.

2. Remove the junction box lid and disconnect the three (3) high voltage wires and the four (4) communication wires.
3. Remove the four (4) screws and o-rings on the main cover and remove the main cover. See Figure 14.
4. Unplug the three-wire harness from the board. See Figure 15.
5. Remove the four (4) screws that secure the electronics enclosure to the motor. See Figure 15.
6. Remove the electronics enclosure and mount the new electronics enclosure using the four (4) screws that secure it to the motor. See Figure 15.
7. Plug the three-wire harness into the connector on the board.
8. Replace the main cover using the four (4) screws that secure it in place. See Figure 14.
9. Reconnect the three (3) high voltage wires and the four (4) communication wires.

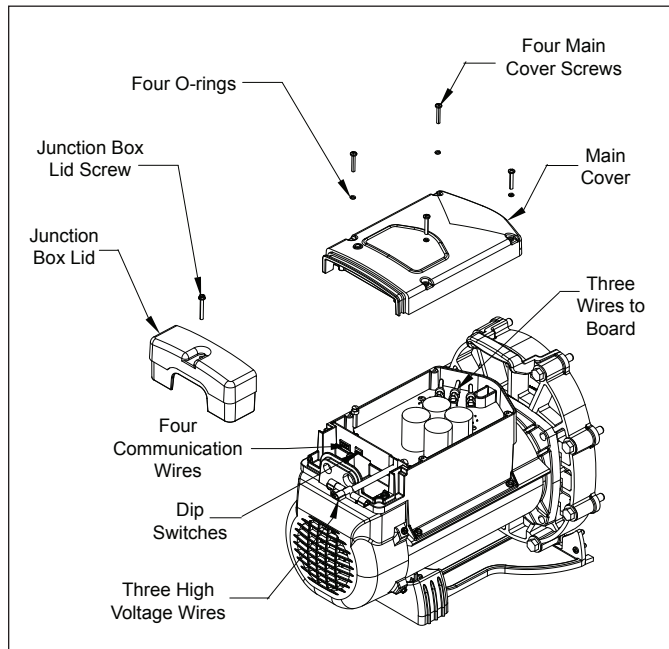

Figure 14. Remove Main Cover for Variable Speed Drive Electronics Unit

CAUTION

IMPORTANT! To prevent potential damage to the ePump, AquaLink® RS, or AquaLink® PDA, set the dip switches to the same settings used in the previous Variable Drive Electronics Unit.

10. Set the dip switches to the same settings set in the previous Variable Speed Drive Electronics Unit. See *Section 3.3, ePump Dipswitch Settings*.
11. Re-install the junction box lid.

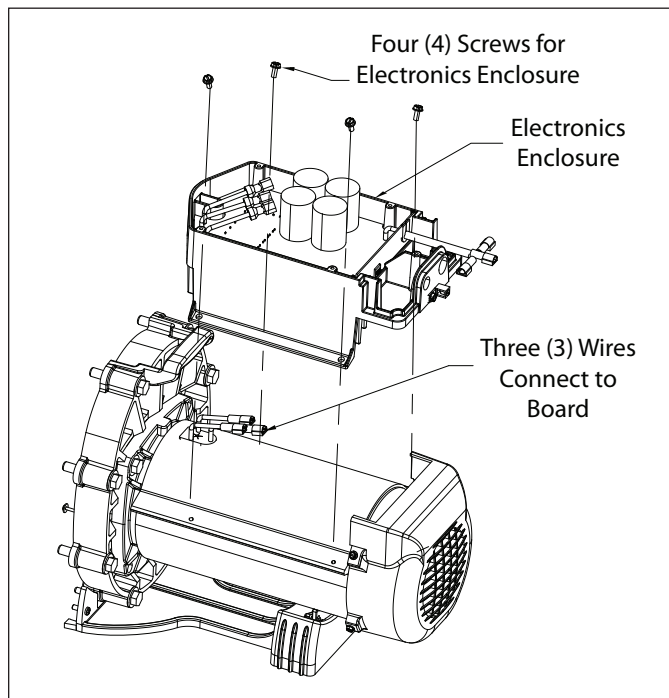

Figure 15. Remove Variable Speed Drive Electronics Enclosure

6.2.5 Motor Replacement

⚠ WARNING

To ensure continued safety and reliable operation, Zodiac Pool Systems, Inc. requires that you replace the motor with a motor that has the identical HP rating and service factor (Zodiac Pool Systems, Inc. approved unit only).

1. Have a qualified service technician or electrician properly disconnect the electrical wiring at the pump motor.

⚠ WARNING

ELECTRICAL SHOCK HAZARD

Turn off all switches and the main breaker in the ePump electrical circuit before starting the procedure. Wait five (5) minutes after power is disconnected before opening motor. Do not proceed until the LED on top of the Drive Electronics Unit is completely off. Failure to comply may cause a shock hazard, resulting in severe personal injury or death.

2. To detach the pump housing from the motor, follow Steps 1 through 10 in *Section 6.2.2, Impeller Removal and Replacement*.
3. Remove the four (4) screws on the main cover and remove the main cover. See Figure 14.
4. Note the alignment of the backplate to the motor, as shown in Figure 16. Place the backplate motor assembly o-ring side down, unscrew the four 9/16" screws, and remove the motor.
5. If installing a new motor, remove the protective plastic cap from the motor shaft. Place the motor on the backplate so that the opening in the motor faces the bottom of the backplate. The electronics controller on the motor should be at the 12 o'clock position.
6. Replace the four (4) bolts and washers holding the backplate to the motor.
7. To reassemble the backplate assembly to the housing, follow Steps 2 through 9 of *Section 6.2.2.1, Impeller Reassembly*.
8. If the pump is located above the water level of the pool, remove the lid and fill the basket with water before starting the pump.
9. To help prevent an air leak into the system, remove any debris around the lid seal seat.
10. **Hand-tighten** the lid to make an air tight seal. **Do not use any tools to tighten the lid.**

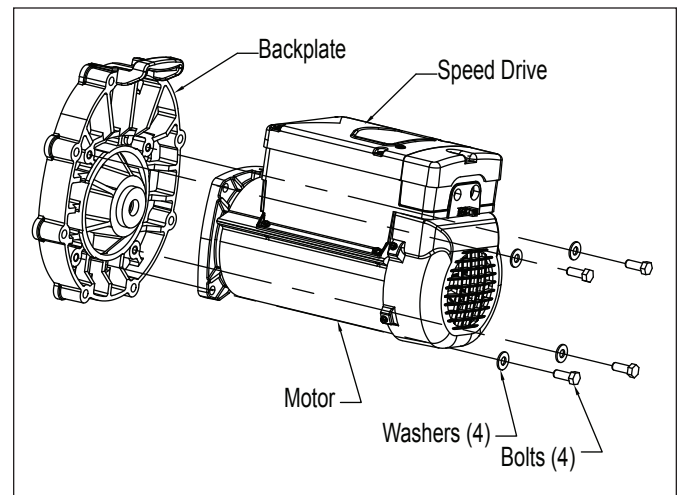

Figure 16. Backplate Assembly

11. Open the pressure release valve on the filter and make sure it is clean and ready for operation.
12. Have a qualified service technician or electrician properly connect the electrical wiring at the pump motor.
13. Turn on the electrical power to the pump motor using your controller and check the system for normal operation.

NOTE For instructions on operating the controller, refer to the appropriate manual for your controller: the ePump Controller Owner's Manual, H0311200, the AquaLink® RS Owner's Manual, 6593, or the AquaLink® PDA Owner's Manual, H0572300C.

14. Once all the air has left the filter, close the pressure relief valve.

NOTE Zodiac Pool Systems, Inc. recommends that the mechanical seals be replaced at the same time the motor is replaced. See *Section 6.2.3, Mechanical Seal Replacement*, for details.

Section 7. Product Specifications and Technical Data

7.1 Replacement Parts List and Exploded View

To order or purchase parts for Jandy pumps, contact your nearest Jandy dealer. You can also contact the Jandy Customer Service Department at 800.822.7933, or send an e-mail message to info@jandy.com.

Key No.	Description	Model No.	Part No.
1	Motor, ePump Series Replacement Kit	JEP2.0	R0474403
1	Motor, ePump Series Replacement Kit	JEP1.5	R0474402
2	Backplate, Pump, SHP, PHP/MHP Replacement Kit	All	R0445200
3	Impeller, Assembly, SHP, PHP, JEP	JEP2.0	R0445305
3	Impeller, Assembly, SHP, PHP, JEP	JEP1.5	R0445304
4	Diffuser with O-ring and Hardware	All	R0445400
5	Mechanical Seals (Carbon and Ceramic)	All	R0479400
6	Body, Pump	All	R0445601
7	Motor Mounting Foot Assembly, SHP	All	R0445700
8	Locking Ring (With Lid and O-ring)	All	R0445800
9	Filter Basket	All	R0445900
10	Plug, Drain (Set of 2)	All	R0446000
11	Tail Piece (2" by 2½") with Union Nut and O-ring (Set of 2)	JEP2.0, JEP1.5	R0446101
12	Seal, Lid	All	R0446200
13	Blue Pressure Test O-ring	All	R0479000
14	O-ring, Backplate	All	R0446300
15	O-ring, Tail Piece (Set of 2)	All	R0446400
16	Diffuser/Impeller Hardware Set	All	R0446500
17	Backplate Hardware with Set of 8 Bolts and Washers	All	R0446600
18	Motor Hardware with Set of 4 Bolts and Washers	All	R0446700
19	Screws, Motor Mounting Foot (Set of 2)	All	R0446800
20	Speed Drive (w/Cover & Hardware), ePump, Replacement Kit	All	R0474900
21	Cover Speed Drive (w/ Hardware), ePump	All	R0475000
22	Cover Fan, 1-3 HP, ePump Replacement Kit	All	R0474800
23	Hardware Speed Drive, ePump	All	R0475100
24	Connector, Speed Drive, ePump (4-Pin Connector)	All	R0660900

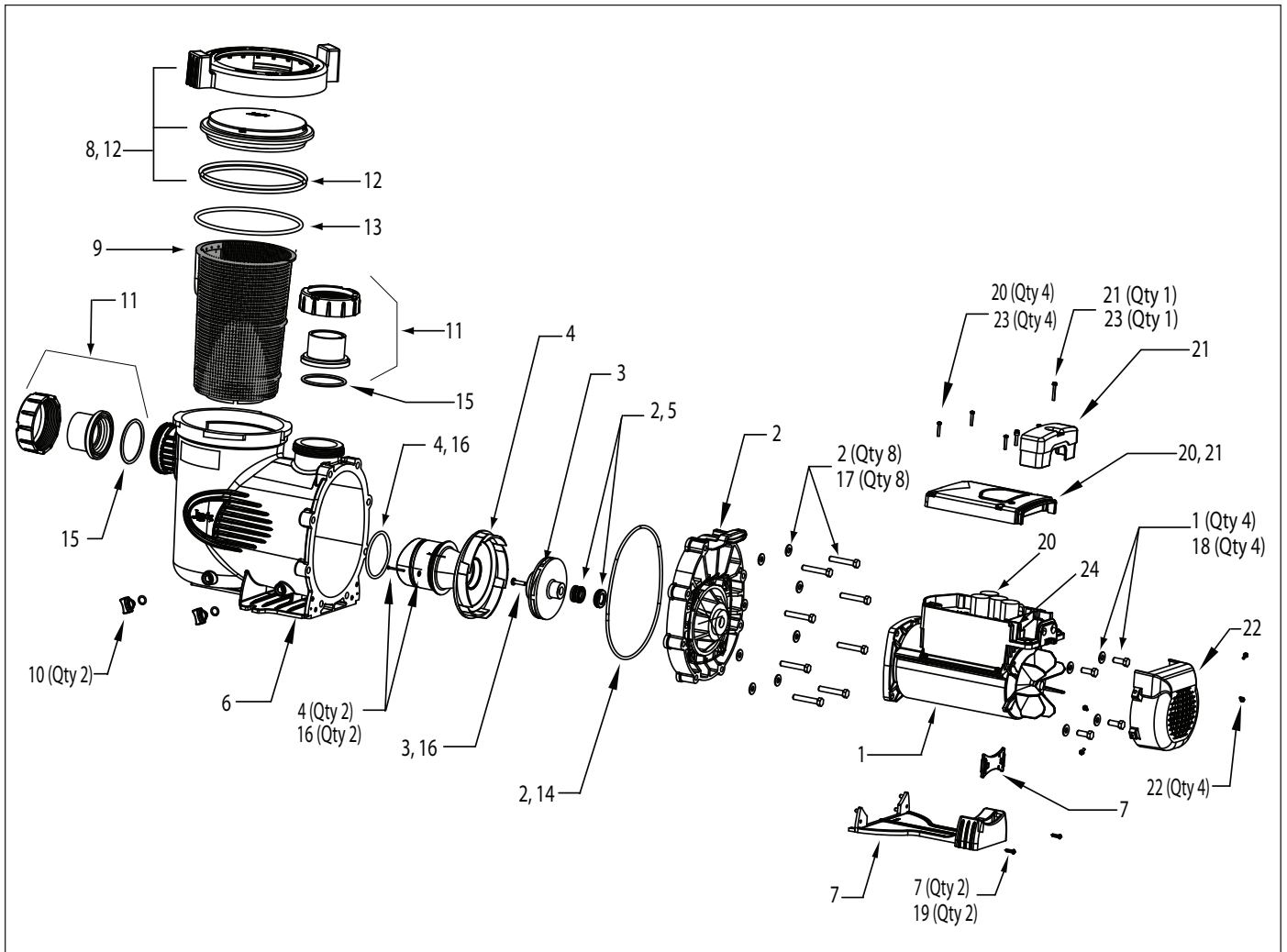
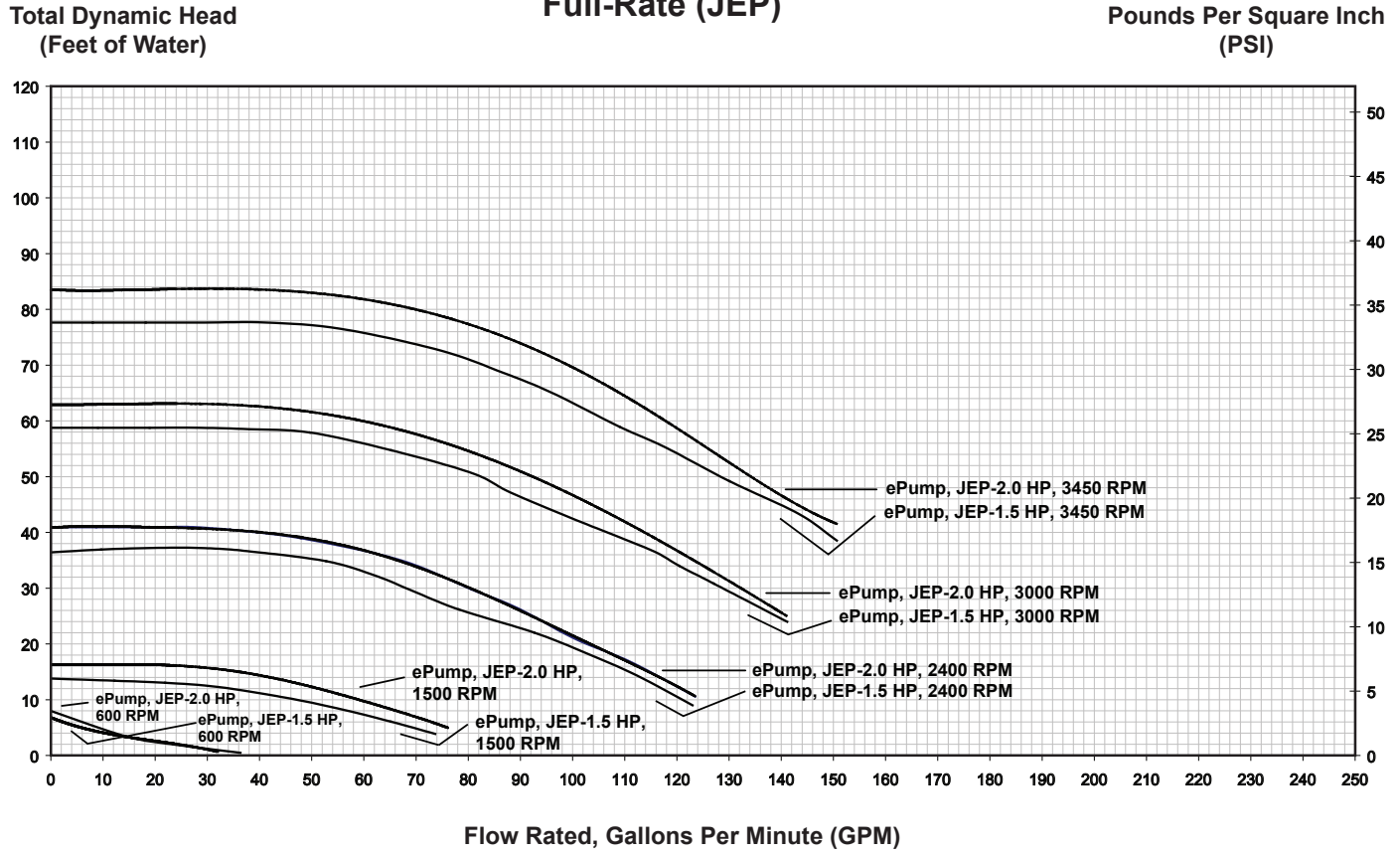

Figure 17. ePump Exploded View

7.2 Performance Curves

Jandy ePump Series High Head Pumps Full-Rate (JEP)



7.3 Physical and Operational Specifications

7.3.1 Specifications

Model No.	HP	Voltage	Watts	Pipe Size	Carton Weight	Overall Length 'A'
JEP2.0	0.25 - 2.7	230 VAC	2,250 W	2½ - 3"	50 lbs.	34¼"
JEP1.5	0.25 - 2.2	230 VAC	2,100 W	2½ - 3"	50 lbs.	34¼"

7.3.2 Dimensions

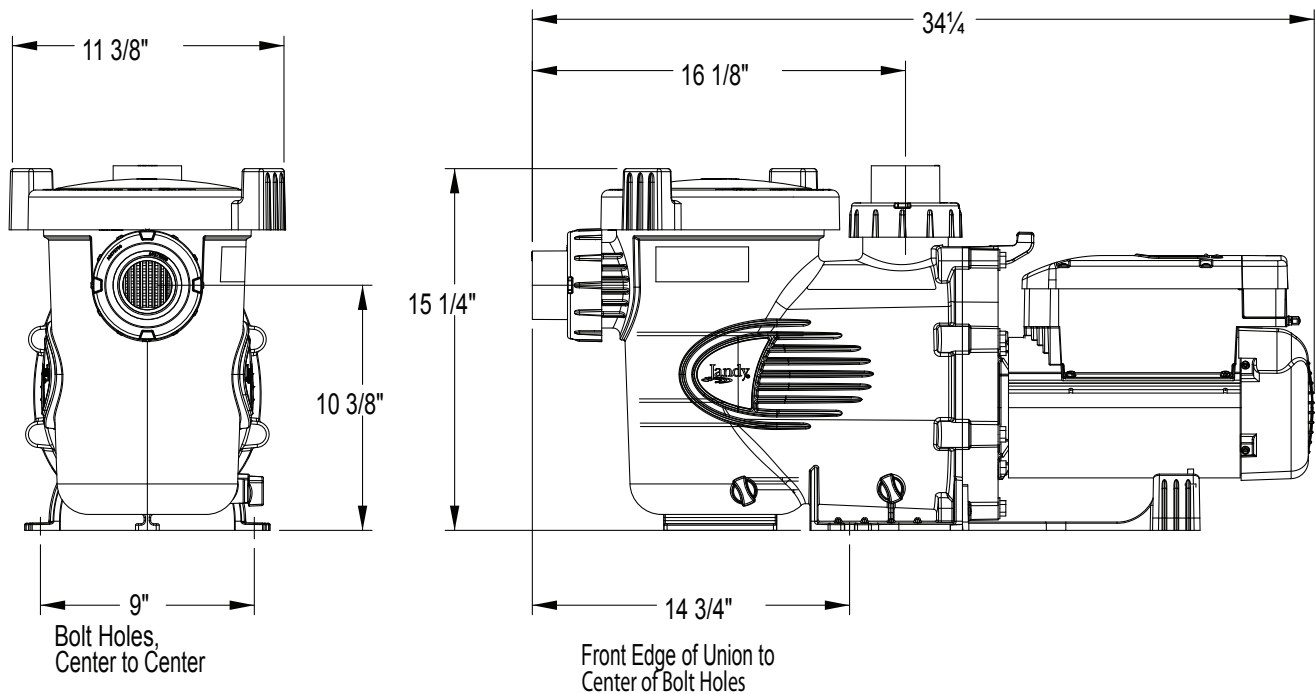

NOTE When installing a pump, leave a minimum of two feet (2 ft) of clearance above the pump for removal of the strainer basket.

7.4 Replacement Motor Guide

Pump Model	A.O. Smith/Century
JEP2.0	M48A40D58
JEP1.5	M48A42D58

LIMITED WARRANTY

Thank you for purchasing Jandy® pool and spa products. Zodiac Pool Systems, Inc. warrants all parts to be free from manufacturing defects in materials and workmanship for a period of one (1) year from the date of retail purchase, with the following exceptions:

- AquaLink® RS units installed with Jandy® Surge Protection Kits will be covered for two (2) years.
- Never Lube® valves are warranted for the life of the pool and/or spa on which they were originally installed.
- AquaPure® Electronic Chlorine Generator Electrolytic Cells carry a five (5) year limited warranty on a prorated basis.
- Heat pumps are covered for two (2) years. There is a lifetime warranty on titanium tubing.
- The heat pump compressor is covered for five (5) years.
- The DuoClear® Electrolytic Cells carry a three (3) year limited warranty on a prorated basis.
- The DuoClear® Vessels carry a three (3) year limited warranty.

This warranty is limited to the first retail purchaser, is not transferable, and does not apply to products that have been moved from their original installation sites. The liability of Zodiac Pool Systems, Inc. shall not exceed the repair or replacement of defective parts and does not include any costs for labor to remove and reinstall the defective part, transportation to or from the factory, or any other materials required to make the repair. Refrigerant or other expendables are not covered by the warranty. This warranty does not cover failures or malfunctions resulting from the following:

1. Failure to properly install, operate, or maintain the product(s) in accordance with our published Installation, Operation, and Maintenance Manuals, which are provided with the product(s).
2. The workmanship of any installer of the product(s).
3. Not maintaining a proper chemical balance in your pool and/or spa [pH levels between 7.2 and 7.8, with ideal ranges being between 7.4 and 7.6, Total Alkalinity (TA) between 80 to 120 ppm, Total Dissolved Solids (TDS) less than 2000, not including salt ppm].
4. Abuse, alteration, accident, fire, flood, lightning, rodents, insects, negligence, or acts of God.
5. Scaling, freezing, or other conditions causing inadequate water circulation.
6. Operating the product(s) at water flow rates outside the published minimum and maximum specifications.
7. Use of non-factory authorized parts or accessories in conjunction with the product(s).
8. Chemical contamination of combustion air or improper use of sanitizing chemicals, such as introducing sanitizing chemicals upstream of the heater and cleaner hose or through the skimmer.
9. Overheating; incorrect wire runs; improper electrical supply; collateral damage caused by failure of O-rings, DE grids, or cartridge elements; or damage caused by running the pump with insufficient quantities of water.

LIMITATION OF LIABILITY:

This is the only warranty given by Zodiac Pool Systems, Inc. No one is authorized to make any other warranties on behalf of Zodiac Pool Systems, Inc. **THIS WARRANTY IS IN LIEU OF ALL OTHER WARRANTIES, EXPRESSED OR IMPLIED, INCLUDING, BUT NOT LIMITED TO, ANY IMPLIED WARRANTIES OF FITNESS FOR A PARTICULAR PURPOSE AND MERCHANTABILITY. ZODIAC POOL SYSTEMS, INC. EXPRESSLY DISCLAIMS AND EXCLUDES ANY LIABILITY FOR CONSEQUENTIAL, INCIDENTAL, INDIRECT, OR PUNITIVE DAMAGES FOR BREACH OF ANY EXPRESSED OR IMPLIED WARRANTY.** This warranty gives you specific legal rights. You may also have other rights that vary by state or province.

WARRANTY CLAIMS:

For prompt warranty consideration, contact your dealer and provide the following information: proof of purchase, model number, serial number, and date of installation. The installer will contact the factory to obtain instructions regarding the claim and to determine the location of the nearest designated service center. If the dealer is not available, you can locate a service center in your area by visiting www.jandy.com or by calling our technical support department at 1.800.822.7933 in the United States or 1.888.647.4004 in Canada. All returned parts must have a Returned Material Authorization number to be evaluated under the terms of this warranty.



Zodiac Pool Systems, Inc.
6000 Condor Drive, Moorpark, CA, USA 93021 • 800.822.7933 FAX 877.327.1403

Litho in USA © 2009 Zodiac Pool Systems, Inc. 0906